



CRIMPING TABLE

5.G.U.TA.190

TABELLA DI PRESSATURA

Compiled	G.S.	Approved	S.M.
Issued	02/10/2012	REV	00
Revised		Sheet 1 of 1	

HOSE						FERRULE		CRIMPING PARAMETERS					
Family	Description	Short Code	ID mm	ID Inch	ID Dash	Product Code	SAP Code	Internal Skive Length $+1/-0$ mm	Internal Skive Dia $\pm 0,4$ mm	External Skive Length $+1/-0$ mm	External Skive Dia $\pm 0,4$ mm	L minimum mark mm	Crimping Dia $\pm 0,1$ mm
ABT5KP MT	ABT5KP-4S	8V9	19	3/4	12	H1400200-120000	1201503	15,0	22,6	52,0	28,2	0,0	33,6
ABT5KP MT	ABT5KP-4S	8V9	25	1	16	H1400200-160000	1201504	17,0	29,6	65,0	35,4	0,0	42,0

CRIMP CHART VALUES ALSO APPLICABLE TO THE FOLLOWING HOSES :

Family	Short Code

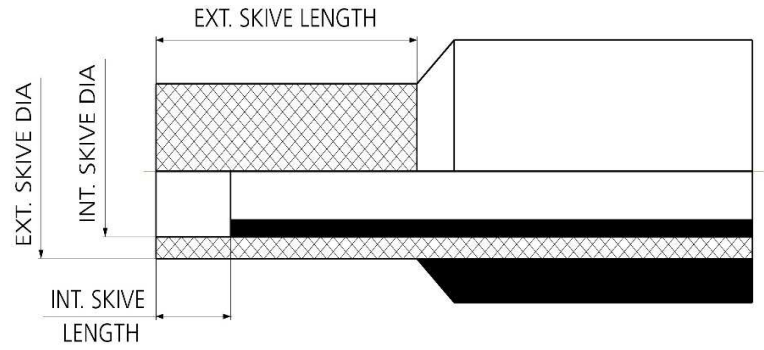

HOSE						FERRULE		CRIMPING PARAMETERS					
Family	Description	Short Code	ID mm	ID Inch	ID Dash	Product Code	SAP Code	Internal Skive Length +1/-0 mm	Internal Skive Dia ±0,4 mm	External Skive Length +1/-0 mm	External Skive Dia ±0,4 mm	L minimum mark mm	Crimping Dia ±0,1 mm
ABT6K MT	ABT6K-4S	8V3	16	5/8	10	H1400301-100000	1202585	15,0	20,3	50,0	25,4	0,0	31,7
ABT6K MT	ABT6K-4S	8V3	19	3/4	12	H1400200-120000	1201503	15,0	22,8	52,0	28,6	0,0	34,0
ABT6K MT	ABT6K-4S	8V3	25	1	16	H1400200-160000	1201504	17,0	29,3	65,0	35,4	0,0	# 42,0
ABT6K MT	ABT6K-4S	8V3	25	1	16	H1400200-160000	1201504	17,0	29,3	65,0	35,8	0,0	* 41,7
ABT6K MT	ABT6K-4S	8V3	32	1 1/4	20	H1400301-200000	1201761	21,5	36,7	74,0	43,3	0,0	53,2
ABT6K MT	ABT6K-6S	8V3	32	1 1/4	20	H1400301-200000	1201761	21,5	37,9	74,0	46,5	0,0	55,6
ABT6K MT	ABT6K-6S	8V3	38	1 1/2	24	H1400301-240000	1201805	22,0	43,9	81,0	53,7	0,0	63,2

CRIMP CHART VALUES ALSO APPLICABLE TO THE FOLLOWING HOSES :

Family	Short Code
ABT6K-4S-STF	8I6
ABT6K-4S-STF	8Z2
ABT6K-4S	8X6

CRIMPING DIAMETER VALID FOR HOSE MARKED UNTIL END 2014

* CRIMPING DIAMETER VALID FOR HOSE MARKED FROM 2015

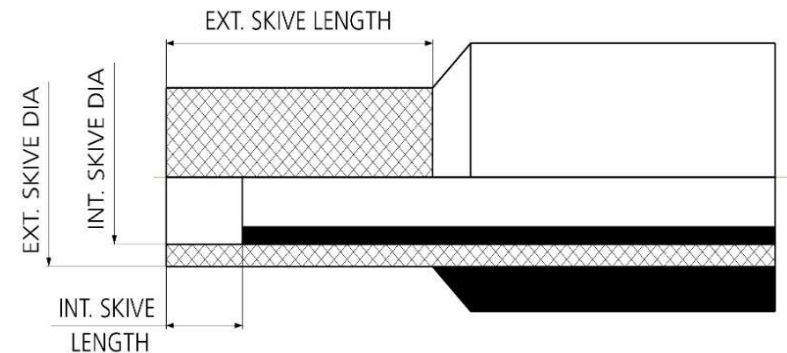

Compiled	G.S.	Approved	S.M.
Issued	02/10/2012	REV	04
Revised	02/04/2014	Sheet 1 of 1	

HOSE						FERRULE		CRIMPING PARAMETERS					
Family	Description	Short Code	ID mm	ID Inch	ID Dash	Product Code	SAP Code	Internal Skive Length +1/-0 mm	Internal Skive Dia ±0,4 mm	External Skive Length +1/-0 mm	External Skive Dia ±0,4 mm	L minimum mark mm	Crimping Dia ±0,1 mm
ABT6K MT	ABT6K-4S	8V3	6	1/4	04	H1100404-040000	1202719	0,0	0,0	19,0	14,7	0,0	18,3
ABT6K MT	ABT6K-4S	8V3	10	3/8	06	H1100404-060000	1203253	0,0	0,0	19,0	17,5	0,0	22,0
ABT6K MT	ABT6K-4S	8V3	13	1/2	08	H1100404-080000	1203266	0,0	0,0	25,0	20,2	0,0	26,3

CRIMP CHART VALUES ALSO APPLICABLE TO THE FOLLOWING HOSES :

Family	Short Code
ABT6K-STF	8I6
ABT7K-MT	8Y3

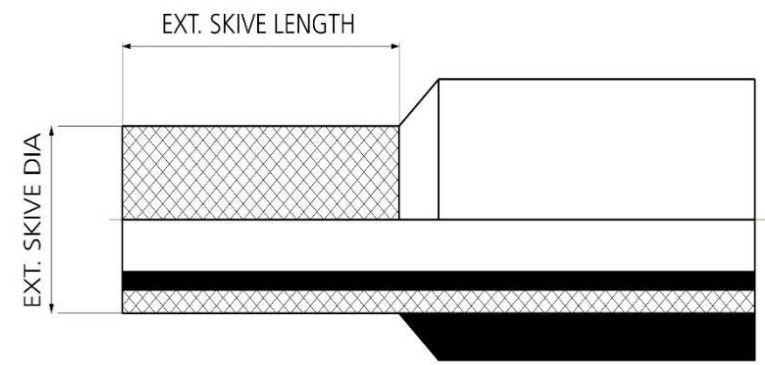



CRIMPING TABLE

5.G.U.TA.207

TABELLA DI PRESSATURA

Compiled	G.S.	Approved	S.M.
Issued	10/01/2014	REV	03
Revised	25/03/2016	Sheet 1 of 1	

HOSE						FERRULE		CRIMPING PARAMETERS					
Family	Description	Short Code	ID mm	ID Inch	ID Dash	Product Code	SAP Code	Internal Skive Length +1/-0 mm	Internal Skive Dia ±0,4 mm	External Skive Length +1/-0 mm	External Skive Dia ±0,4 mm	L minimum mark mm	Crimping Dia ±0,1 mm
FXP2	FLEXOPAK2 MT	822	6	1/4	04	H1100SK1-040000	1233077	0,0	0,0	19,0	11,2	0,0	16,3
FXP2	FLEXOPAK2 MT	822	8	5/16	05	H1100SK1-050000	1233078	0,0	0,0	19,0	12,7	0,0	18,1
FXP2	FLEXOPAK2 MT	822	10	3/8	06	H1100SK1-060000	1233079	0,0	0,0	20,0	15,0	0,0	20,1
FXP2	FLEXOPAK2 MT	822	13	1/2	08	H1100SK1-080000	1233080	0,0	0,0	26,0	18,6	0,0	24,3
FXP2	FLEXOPAK2 MT	822	16	5/8	10	H1100SK1-100000	1233081	0,0	0,0	28,0	21,4	0,0	26,8
FXP2	FLEXOPAK2 MT	822	19	3/4	12	H1100SK1-120000	1233082	0,0	0,0	33,0	25,4	0,0	30,8
FXP2	FLEXOPAK2 MT	822	25	1	16	H1100SK1-160000	1233083	0,0	0,0	37,0	33,3	0,0	38,4
FXP2	FLEXOPAK2 MT	822	32	1 1/4	20	H1100404-200000	1234766	0,0	0,0	41,0	39,2	0,0	48,2

CRIMP CHART VALUES ALSO APPLICABLE TO THE FOLLOWING HOSES :

Family	Short Code
FXP2-HT	8X5
FXP2-STF	8A9
FXP2-TWIN	8E5
FXP2-LT	8E6

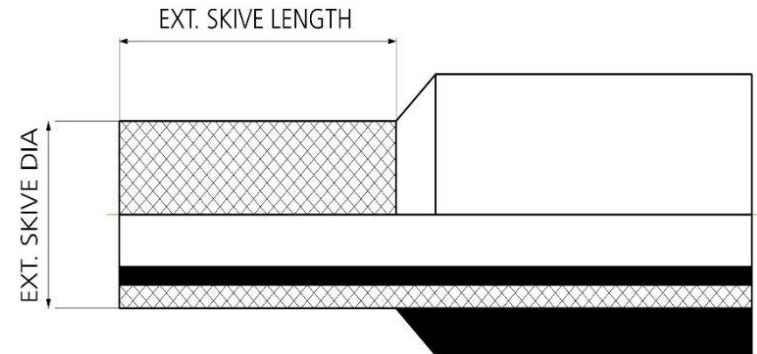

HOSE						FERRULE		CRIMPING PARAMETERS					
Family	Description	Short Code	ID mm	ID Inch	ID Dash	Product Code	SAP Code	Internal Skive Length +1/-0 mm	Internal Skive Dia ±0,4 mm	External Skive Length +1/-0 mm	External Skive Dia ±0,4 mm	L minimum mark mm	Crimping Dia ±0,1 mm
2SN HF	2SN/R2AT HF	8T8	6	1/4	04	H1100404-040000	1202719	0,0	0,0	19,0	12,4	0,0	17,0
2SN HF	2SN/R2AT HF	8T8	8	5/16	05	H1100404-050000	1237390	0,0	0,0	19,0	14,0	0,0	18,9
2SN HF	2SN/R2AT HF	8T8	10	3/8	06	H1100404-060000	1203253	0,0	0,0	19,0	16,3	0,0	21,4
2SN HF	2SN/R2AT HF	8T8	13	1/2	08	H1100404-080000	1203266	0,0	0,0	25,0	19,3	0,0	25,6
2SN HF	2SN/R2AT HF	8T8	16	5/8	10	H1100404-100000	1219132	0,0	0,0	28,0	22,5	0,0	28,2
2SN HF	2SN/R2AT HF	8T8	19	3/4	12	H1100404-120000	1203368	0,0	0,0	33,0	26,6	0,0	32,4
2SN HF	2SN/R2AT HF	8T8	25	1	16	H1100404-160000	1234701	0,0	0,0	37,0	34,4	0,0	40,7
2SN HF	2SN/R2AT HF	8T8	32	1 1/4	20	H1100404-200000	1234766	0,0	0,0	41,0	43,6	0,0	51,0
2SN HF	2SN/R2AT HF	8T8	38	1 1/2	24	H1100404-240000	1234767	0,0	0,0	47,0	50,0	0,0	59,8
2SN HF	2SN/R2AT HF	8T8	51	2	32	H1100404-320000	1234768	0,0	0,0	60,0	62,8	0,0	74,8

CRIMP CHART VALUES ALSO APPLICABLE TO THE FOLLOWING HOSES :

Family	Short Code
2SN-MT	8Z7
2SN-STF	844

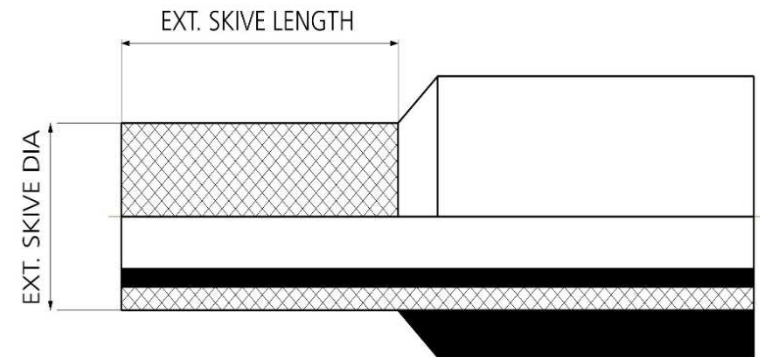



CRIMPING TABLE

5.G.U.TA.008

TABELLA DI PRESSATURA

Compiled	G.S.	Approved	S.M.
Issued	26/04/1995	REV	09
Revised	15/01/2011	Sheet 1 of 1	

HOSE						FERRULE		CRIMPING PARAMETERS					
Family	Description	Short Code	ID mm	ID Inch	ID Dash	Product Code	SAP Code	Internal Skive Length +1/-0 mm	Internal Skive Dia ±0,4 mm	External Skive Length +1/-0 mm	External Skive Dia ±0,4 mm	L minimum mark mm	Crimping Dia ±0,1 mm
4SH	FLEXOR-4SH MT	855	19	3/4	12	H1400200-120000	1201503	15,0	22,8	52,0	28,4	0,0	34,0
4SH	FLEXOR-4SH MT	855	25	1	16	H1400200-160000	1201504	17,0	29,9	65,0	35,4	0,0	42,1
4SH	FLEXOR-4SH MT	855	32	1 1/4	20	H1400200-200000	1200098	21,5	36,7	74,0	42,4	0,0	51,1
4SH	FLEXOR-4SH MT	855	38	1 1/2	24	H1400200-240000	1200099	22,0	42,4	81,0	48,8	0,0	57,1
4SH	FLEXOR-4SH MT	855	51	2	32	H1400200-320000	1201284	29,0	56,3	85,0	63,2	0,0	73,0

CRIMP CHART VALUES ALSO APPLICABLE TO THE FOLLOWING HOSES :

Family	Short Code

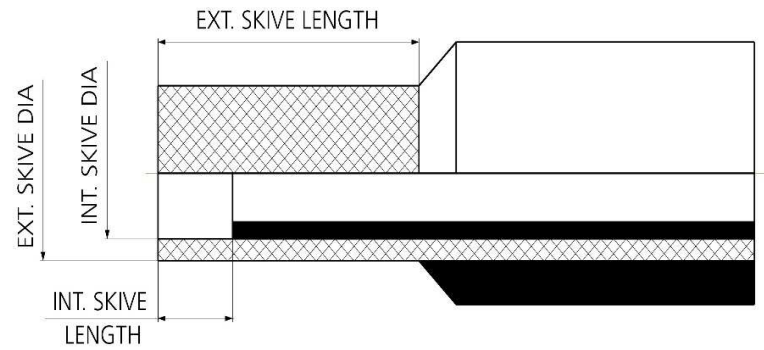



CRIMPING TABLE

5.G.U.TA.174

TABELLA DI PRESSATURA

Compiled	G.S.	Approved	S.M.
Issued	14/06/2011	REV	04
Revised	13/01/2014	Sheet 1 of 1	

HOSE						FERRULE		CRIMPING PARAMETERS					
Family	Description	Short Code	ID mm	ID Inch	ID Dash	Product Code	SAP Code	Internal Skive Length +1/-0 mm	Internal Skive Dia ±0,4 mm	External Skive Length +1/-0 mm	External Skive Dia ±0,4 mm	L minimum mark mm	Crimping Dia ±0,1 mm
2SN HF	2SN/R2AT HF	8T8	5	3/16	03	H1200AD2-030000	1227990	0,0	0,0	0,0	0,0	0,0	16,3
2SN HF	2SN/R2AT HF	8T8	6	1/4	04	H1200AD2-040000	1227991	0,0	0,0	0,0	0,0	0,0	18,2
2SN HF	2SN/R2AT HF	8T8	8	5/16	05	H1200AD2-050000	1227992	0,0	0,0	0,0	0,0	0,0	20,1
2SN HF	2SN/R2AT HF	8T8	10	3/8	06	H1200AD2-060000	1227993	0,0	0,0	0,0	0,0	0,0	22,3
2SN HF	2SN/R2AT HF	8T8	13	1/2	08	H1200AD2-080000	1227994	0,0	0,0	0,0	0,0	0,0	25,4
2SN HF	2SN/R2AT HF	8T8	16	5/8	10	H1200AD2-100000	1227995	0,0	0,0	0,0	0,0	0,0	28,8
2SN HF	2SN/R2AT HF	8T8	19	3/4	12	H1200AD2-120000	1227996	0,0	0,0	0,0	0,0	0,0	32,5
2SN HF	2SN/R2AT HF	8T8	25	1	16	H1200AD2-160000	1227997	0,0	0,0	0,0	0,0	0,0	39,9
2SN HF	2SN/R2AT HF	8T8	32	1 1/4	20	H1200AD2-200000	1227998	0,0	0,0	0,0	0,0	0,0	49,6
2SN HF	2SN/R2AT HF	8T8	38	1 1/2	24	H1200AD2-240000	1227999	0,0	0,0	0,0	0,0	0,0	56,7
2SN HF	2SN/R2AT HF	8T8	51	2	32	H1200AD2-320000	1228000	0,0	0,0	0,0	0,0	0,0	70,8

CRIMP CHART VALUES ALSO APPLICABLE TO THE FOLLOWING HOSES :

Family	Short Code
2SN-MT	8Z7
2SN-STF	844



CRIMPING TABLE

5.G.U.TA.176

TABELLA DI PRESSATURA

Compiled	G.S.	Approved	S.M.
Issued	02/11/2011	REV	03
Revised	11/07/2016	Sheet 1 of 1	

HOSE						FERRULE		CRIMPING PARAMETERS					
Family	Description	Short Code	ID mm	ID Inch	ID Dash	Product Code	SAP Code	Internal Skive Length +1/-0 mm	Internal Skive Dia ±0,4 mm	External Skive Length +1/-0 mm	External Skive Dia ±0,4 mm	L minimum mark mm	Crimping Dia ±0,1 mm
2SC	FLEXOPAK 2SC HF	8N6	6	1/4	04	H1200AD1-040000	1227978	0,0	0,0	0,0	0,0	0,0	17,4
2SC	FLEXOPAK 2SC HF	8N6	8	5/16	05	H1200AD1-050000	1227979	0,0	0,0	0,0	0,0	0,0	19,0
2SC	FLEXOPAK 2SC HF	8N6	10	3/8	06	H1200AD1-060000	1227980	0,0	0,0	0,0	0,0	0,0	21,2
2SC	FLEXOPAK 2SC HF	8N6	13	1/2	08	H1200AD1-080000	1227981	0,0	0,0	0,0	0,0	0,0	24,8
2SC	FLEXOPAK 2SC HF	8N6	16	5/8	10	H1200AD1-100000	1227983	0,0	0,0	0,0	0,0	0,0	27,9
2SC	FLEXOPAK 2SC HF	8N6	19	3/4	12	H1200AD1-120000	1227985	0,0	0,0	0,0	0,0	0,0	31,7
2SC	FLEXOPAK 2SC HF	8N6	25	1	16	H1200AD1-160000	1227986	0,0	0,0	0,0	0,0	0,0	39,4

CRIMP CHART VALUES ALSO APPLICABLE TO THE FOLLOWING HOSES :

Family	Short Code
2SC-MT	8T2
2SC-STF	8X9
2SC-TWIN	8V8
AJ400	8B4AA
AJ400-BLU	8B4AE
AT4K MT	8N1



CRIMPING TABLE

5.G.U.TA.188

TABELLA DI PRESSATURA

Compiled	G.S.	Approved	S.M.
Issued	02/10/2012	REV	04
Revised	21/04/2015	Sheet 1 of 1	

HOSE						FERRULE		CRIMPING PARAMETERS					
Family	Description	Short Code	ID mm	ID Inch	ID Dash	Product Code	SAP Code	Internal Skive Length +1/-0 mm	Internal Skive Dia ±0,4 mm	External Skive Length +1/-0 mm	External Skive Dia ±0,4 mm	L minimum mark mm	Crimping Dia ±0,1 mm
ABT5K MT	ABT5K-4S	8V2	16	5/8	10	H1100404-100000	1219132	0,0	0,0	28,0	23,5	0,0	28,9
ABT5K MT	ABT5K-4S	8V2	19	3/4	12	H1100404-120000	1203368	0,0	0,0	33,0	28,2	0,0	33,3
ABT5K MT	ABT5K-4S	8V2	25	1	16	H1100404-160000	1234701	0,0	0,0	37,0	34,8	0,0	41,2

CRIMP CHART VALUES ALSO APPLICABLE TO THE FOLLOWING HOSES :

Family	Short Code
ABT5K-STF	8Z4

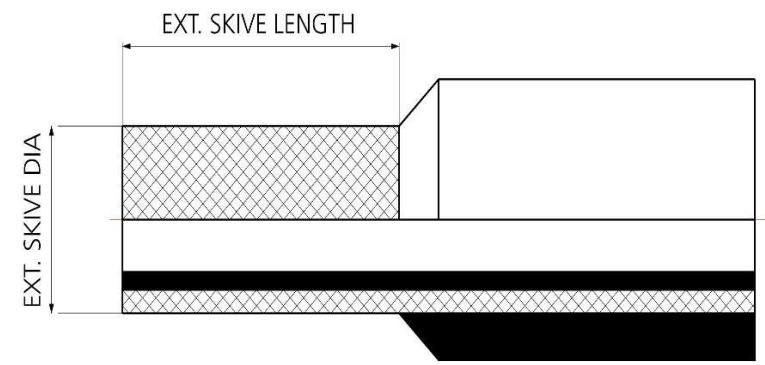

Compiled	G.S.	Approved	S.M.
Issued	02/10/2012	REV	06
Revised	08/10/2015	Sheet 1 of 1	

HOSE						FERRULE		CRIMPING PARAMETERS					
Family	Description	Short Code	ID mm	ID Inch	ID Dash	Product Code	SAP Code	Internal Skive Length +1/-0 mm	Internal Skive Dia ±0,4 mm	External Skive Length +1/-0 mm	External Skive Dia ±0,4 mm	L minimum mark mm	Crimping Dia ±0,1 mm
ABT5K MT	ABT5K-4S	8V2	19	3/4	12	H1400200-120000	1201503	15,0	22,9	52,0	28,2	0,0	33,6
ABT5K MT	ABT5K-4S	8V2	25	1	16	H1400200-160000	1201504	17,0	29,6	65,0	34,8	0,0	41,7
ABT5K MT	ABT5K-4S	8V2	32	1 1/4	20	H1400200-200000	1200098	22,0	35,9	74,0	41,6	0,0	49,7
ABT5K MT	ABT5K-6S	8V2	38	1 1/2	24	H1400301-240000	1201805	22,0	43,9	81,0	53,7	0,0	63,2
ABT5K MT	ABT5K-6S	8V2	51	2	32	H1400301-320000	1202006	29,0	56,6	85,0	67,4	0,0	80,6

CRIMP CHART VALUES ALSO APPLICABLE TO THE FOLLOWING HOSES :

Family	Short Code
ABT5K-STF	8Z4

